

HMI41 Indicator and HMP46 High Temperature Probe



The Vaisala HUMICAP® Humidity Indicator HMI41 equipped with the Vaisala HUMICAP® Humidity and Temperature Probe HMP46 is an ideal combination for spot checking and field calibration.

Features/Benefits

- RH measurement range 0 ... 100 %RH
- Temperature measurement range -40 ... +100 °C (-40 ... +212 °F), for short periods up to +180 °C (+356 °F)
- Calculates dewpoint, wet bulb temperature, absolute humidity and mixing ratio
- Versatile and easy-to-use
- Incorporates Vaisala HUMICAP® Sensor
- Excellent stability
- Data collection with serial line download capability
- NIST traceable (certificate included)
- Optional carrying case and calibration cable
- Available as a complete calibration kit HMK41

The Vaisala HUMICAP® Humidity Indicator HMI41 fitted with the Vaisala HUMICAP® Humidity and Temperature Probe HMP46 can be used for spot checking humidity and temperature in ducts or chambers. Typical applications are plant maintenance, installation and inspection of air conditioning systems, production and storage areas and production processes. In addition, it is suitable for field checking Vaisala's humidity transmitters.

Withstands high temperatures

The HMP46 operates in full humidity range of 0 ... 100 %RH. The temperature range is from -40 to +100 °C (-40 ... +212 °F). For short periods of time, the probe can withstand temperatures up to +180 °C (+356 °F). The HMP46 probe is solid and rugged. Its stainless steel probe is made to withstand rough handling in mechanically demanding applications. The probe's long shaft can also reach otherwise unreachable places.

Versatile and easy to use

In addition to displaying the humidity and temperature readings, the HMI41 indicator calculates dewpoint and wet bulb temperature, absolute humidity and mixing ratio.

The indicator has an easy-to-read two line liquid crystal display. The display units (metric or non-metric) are easily selected.

These features, plus fast response time, high measurement accuracy and excellent stability, as well as the wide temperature range of the probe, make the HMI41/HMP46 combination an ideal choice for the most demanding applications.

High performance sensor

The HMP46 probe incorporates Vaisala HUMICAP® Sensor. This sensor has high accuracy, excellent long-term stability and negligible hysteresis. In addition, the sensor is insensitive to dust, particulate dirt and most chemicals.

Technical Data

HMI41 indicator

Calculated variables	dewpoint temperature, absolute humidity, wet bulb temperature, mixing ratio
Resolution	0.1 %RH; 0.1 °C/°F
Power supply	4 batteries, type AA (LR 6)
Battery operation time (alkaline batteries)	72 h continuous use
Auto-off function	
Operating temperature	-20 ... +60 °C (-4 ... +140 °F)
Storage temperature	-40 ... +70 °C (-40 ... +158 °F)
Display	two line LCD
Housing material	ABS plastic
Housing classification	IP53 (with connectors blocked)
Weight (incl. batteries)	300 g
Maximum measurement error of indicator at +20 °C	
humidity	±0.1 %RH
temperature	±0.1 °C (±0.18 °F)

HMP46 probe

Humidity	
Measurement range	0 ... 100 %RH, non-condensing
Accuracy (incl. nonlinearity, hysteresis and repeatability) at +20 °C	
Maximum achievable accuracy when calibrated against high quality, certified humidity standards:	
0 ... 90 %RH	±1 %RH
90 ... 100 %RH	±2 %RH
When calibrated against salt solutions (ASTM E104-85)	
0 ... 90 %RH	±2 %RH
90 ... 100 %RH	±3 %RH

Temperature Dependence

error %RH

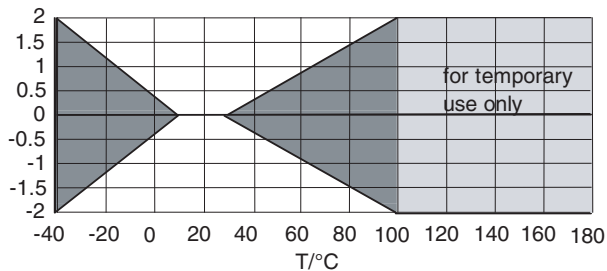

Typical long-term stability	better than 1 %RH per year
Response time (90%) at +20°C in still air w/sintered filter	15 s
Humidity sensor	HUMICAP® 180

Temperature

Continuous measurement	-40 ... +100 °C (-40 ... +212 °F)
Short-term measurement	-40 ... +180 °C (-40 ... +356 °F)
Accuracy at +20 °C (+68 °F)	±0.2 °C (±0.36 °F)
Accuracy over the measurement range	

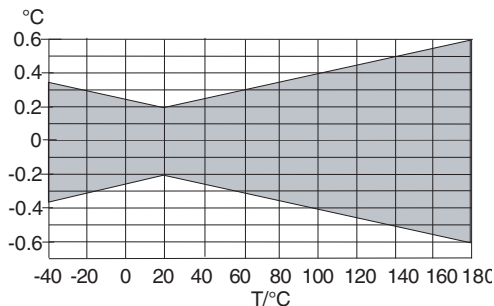

Temperature sensor	Pt 100 IEC 751 1/3 class B
--------------------	----------------------------

General

Typical ranges of calculated variables	
dewpoint temperature	-20 ... +100 °C (-4 ... +100 °F)
absolute humidity	0 ... 600 g/m ³
wet bulb temperature	0 ... 100 °C (32 ... 212 °F)
mixing ratio	0 ... 600 g/kg d.a.
The accuracies of these calculated variables are limited by the accuracies of the measured variables on which they are based, namely RH and T. The RH and T accuracies are stated under HMP46 probe.	
Cable length	1500 mm; extended spiral cable
Operating temperature range for electronics	-20 ... +60 °C (-4 ... +140 °F)
Housing material	
Electronics housing	ABS plastic
Probe	stainless steel
Housing classification	
electronics	IP65 (NEMA 4)
Sensor protection	sintered filter, part no. 0195
option membrane filter, part no. 10159HM (max +80 °C / +176 °F)	
plastic grid, part no. 6221 (max +80 °C / +176 °F)	
Weight	450 g
Electromagnetic compatibility	Complies with EMC standard EN61326-1, Portable Equipment

Accessories

Transmitter calibration cables	
Cable Part #	for Calibrating
19116ZZ	HM60/70's, HM140's, HMM22D, HMW61/71
19164ZZ	HMP230's, HMM210
19165ZZ	HM20/30's, HMP130's, HMM30C
25916ZZ	HMT360's for use in 'safe' zones
25917ZZ	HMT330's
Carrying case for HMI41 & HMP46	
plastic	part no. 210614
aluminum	part no. MI70CASE2
Serial communication cable	part no. 19446ZZ

Dimensions

Dimensions in mm.

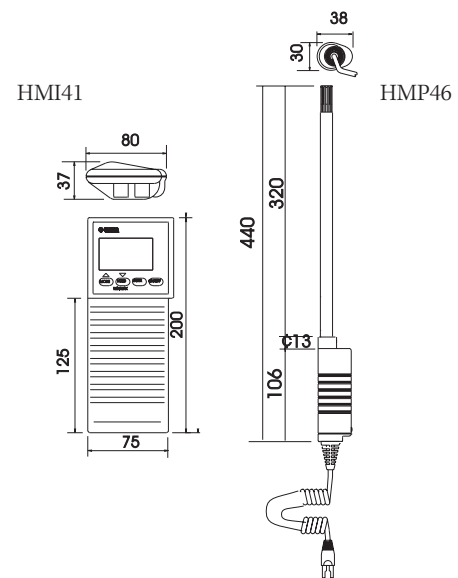

HUMICAP® is a registered trademark of Vaisala. Specifications subject to change without prior notice. © Vaisala Oyj

