

*The 6200B combines the key microwave instruments for scalar network measurements, power and frequency measurements in a compact and portable product*



- **Precision Scalar Network measurements**
- **Integral Frequency Counter and Power Meter**
- **Real time Fault Location with 0.1% accuracy**
- **Economical, compact and portable**
- **2 GHz, 8 GHz, 20 GHz, 26.5 GHz and 46 GHz versions**
- **Synthesized signal source with optional step attenuator**
- **3.5 in disk drive for results storage**
- **Dynamic calibrator and EEPROM corrected detectors for accurate measurements**
- **6210 Reflection Analyzer for precision reflection coefficient and time domain measurements**

The 6200B series RF and Microwave Test Sets (MTS) are an innovative range of instruments. An MTS combines the key microwave instruments for scalar network measurements, power and frequency measurements into a compact and portable product. Powerful fault location software adds the ability to measure return loss (VSWR) against distance to speed up fault identification on coaxial or waveguide transmission lines.

Integration offers many benefits over an assembly of discrete instruments. A single user interface makes operation faster and simpler. Measurements can be configured and changed

quickly as fewer instrument connections are necessary. A single display can show a multitude of parameters making results viewing easier, and more reliable. Capital costs are reduced as the MTS provides an economical way of providing a comprehensive test solution.

#### Targeted Frequency Versions

Five versions of the MTS are available so that users can select the unit that exactly matches their requirements. The 6202B RF Test Set covers 10 MHz to 2 GHz and is ideal for manufacturers of components for the mobile communications industry. Its light weight and small size also make 6202B the ideal instrument for field engineers installing and maintaining mobile radio antenna and antenna feeders.

8 GHz, 20 GHz and 26.5 GHz versions are available for users in the major microwave bands. A 46 GHz instrument is provided for those users working on the increasingly important millimetric bands. A comprehensive range of accessories is available to support each of these units.

#### Development

The flexibility and accuracy of the 6200B series MTS make it an excellent instrument for the development engineer. A synthesized signal source with 1 Hz resolution can be used as both a CW source or synthesized sweep generator. A new OCXO frequency standard provides high stability frequency settings and measurements. New 6230A/L series scalar detectors with EEPROM correction and a new dynamic calibrator give power meter accuracy even during swept frequency measurements. The dynamic calibrator in the 6200B characterizes the detector linearity enabling precision insertion loss measurements.

An integral voltage/current source can be used to bias devices such as PIN diodes or to provide a swept voltage stimulus for characterizing VCO's. The integral frequency counter of the MTS allows the unique graphical display of frequency as a function of swept voltage.

The integrated nature of the 6200B series means that a wide range of devices can be characterized with a single test instrument, reducing bench clutter.

For engineers who demand the best possible accuracy when measuring

To receive a calibration and/or repair quote-RMA from R.A.E. Services Inc.  
Click here>> [www.raeservices.com/services/quote.htm](http://www.raeservices.com/services/quote.htm)

reflection coefficient, the addition of a 6210 Reflection Analyzer to a standard 6200B series MTS provides error corrected measurement of reflection coefficient ( $S^{11}$ ). 6210 also gives Smith Chart displays and Time Domain measurements as standard.

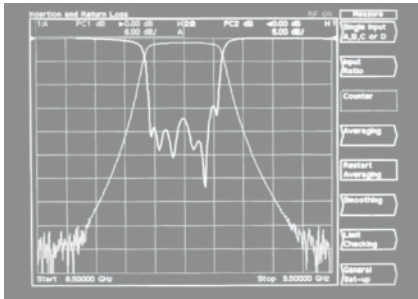

### Production

6200B series MTS reduces production test time, simplifies the generation of test methods and test programs, at a reduced capital cost.

All aspects of the 6200B can be controlled through the GPIB, IEEE 488.2, interface. Space requirement in a test rack is reduced due to the small volume of the MTS.

The improved scalar network analyzer performance of the 6200B series means that production stand-offs can be reduced resulting in greater production yield.

A macro facility automates and customizes many measurement procedures. Repetitive test methods can be stored into memory along with production limits and operator prompts. Branching and looping within macros means that test methods can allow for device tuning and adjustment. An external keyboard can be connected via a standard keyboard interface to simplify macro editing and generation of operator instructions.

Operator errors are reduced due to the simplified nature of the test set up. New test methods are quickly learned as only one instrument is necessary to test a wide variety of devices.

### Installation and Maintenance

The integrity of modern communication systems depends upon a correctly installed and well maintained radio network. Microwave links, satellite earth stations and RF communications networks such as analog and digital cellular radio all require antennas and antenna feeders. Maintaining the performance of the antenna and its feed is essential for reliable communications.

6200B series MTS measures the return loss (sometimes measured in terms of VSWR) and insertion loss of antennas and feeders. In the event of an out of specification return loss measurement the MTS can perform a fault location measurement. This gives a display of return loss (or VSWR) against distance, pinpointing the position of all causes of reflection in the antenna and feeder. From this display the field engineer can quickly identify the component or position along the transmission line at fault and expedite a repair.

The new 6240 series Fault Locators offer a small ruggedized solution for the measurement of return loss and fault location. Both measurements can be made simultaneously from a single test port speeding up and simplifying the characterisation of antennas and antenna feeders. A guided measurements application leads the test engineer through the most common field measurements. The application assists in setting up and calibrating the measurement through a series of operator prompts and on screen diagrams. This results in fast, accurate and repeatable measurements.

### APPLICATIONS

#### Insertion Loss and Return Loss Measurement Using a Reference Channel

The diagram shows the basic set up to measure insertion loss and return loss for common components such as filters and attenuators using an autotester and detectors. A 6230A series detector will give over 70 dB dynamic range for insertion loss measurements. Use of an autotester provides wide frequency bandwidth coupled with excellent directivity for precise return loss measurements.

In this set up a power splitter is used to monitor the power close to the measurement port. This is especially important when a cable is used between the source output and the autotester input. The reference channel reduces the effects of the error due to source mismatch which is seen as a ripple superimposed on the measurement.

Any variations in the DUT input level are measured by the reference channel and the MTS compensates for the variation by ratioing the reference signal with the reflected and transmitted signal measurements. This reduces mismatch ripples caused by multiple reflections. The 6230L series detectors are ideal for the measurement of low loss devices such as semi-rigid coaxial cables or inband filters. This is because the excellent input VSWR of the 6230L series detectors minimizes mismatch between the DUT and the detector.

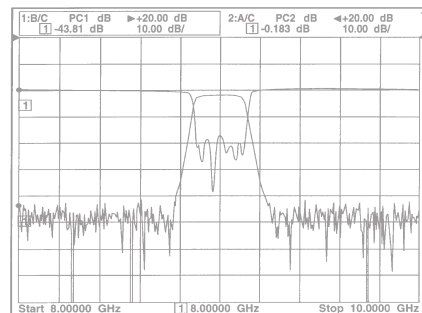

Filter measurement with live reference

#### Amplifier Gain Compression Measurement

This measurement set up can be used to determine the power handling capacity of an amplifier. This is achieved by measuring the 1 dB compression point of an amplifier. Detector B is configured to monitor the incident power to the amplifier while detector A measures the output power. The 6230L series detectors are recommended due to their power handling capability and accuracy. A coupler is used to sense the incident power, so that most of the

To receive a calibration and/or repair quote-RMA from R.A.E. Services Inc.  
 Click here>> [www.raeservices.com/services/quote.htm](http://www.raeservices.com/services/quote.htm)

available power from the source can be used to drive the amplifier into compression.

A special gain compression application enables the 6200B series MTS to measure the gain compression of an amplifier against frequency. The gain compression application generates this display quickly and easily with minimal user interaction, completing a 401 frequency point measurement typically in under 30 seconds. This application is especially useful in the design and production of broadband amplifiers.

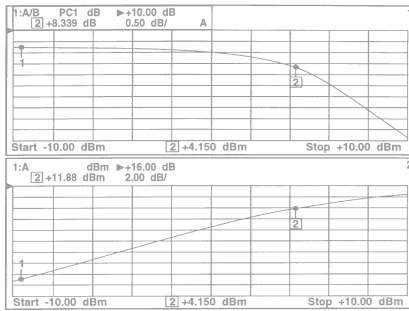

Amplifier gain compression test, showing normalized gain (top) and output power (bottom) of amplifier

### VCO Characterization

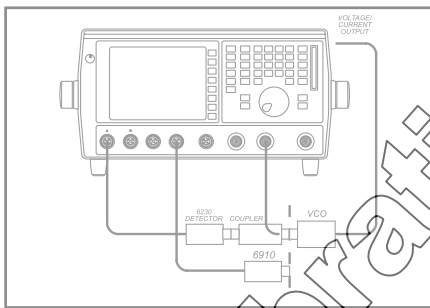

The diagram shows the set up required to characterize a voltage controlled oscillator (VCO). This is achieved by determining the maximum and minimum frequencies of operation, the frequency linearity and measuring the output power against tuning voltage of the device. The unique capability of the 6200B series MTS to measure frequency against tuning voltage of a VCO speeds up production test and reduces bench clutter.

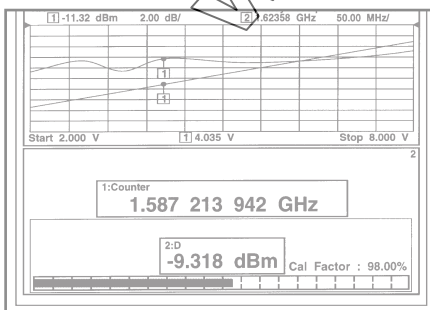

VCO swept voltage characteristics, showing output power and frequency against tuning voltage

### Simultaneous Return Loss and Fault Location Measurement

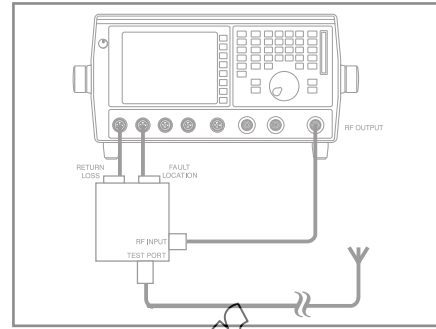

The diagram shows the set up used to make a simultaneous return loss and fault location measurement. A typical application would be to measure the performance of an antenna and antenna feeder, coaxial or waveguide. New RF communications systems, such as analog and digital cellular radio networks, and standard microwave links can have antenna feeds up to 100 metres long. Good system performance is dependent on a correctly installed and maintained antenna and antenna feeder. The fault locator measures both fault location and return loss from a single test port. It is small and lightweight and therefore ideal for field use. Both measurements can be displayed simultaneously using the dual channel mode on the MTS as shown below.

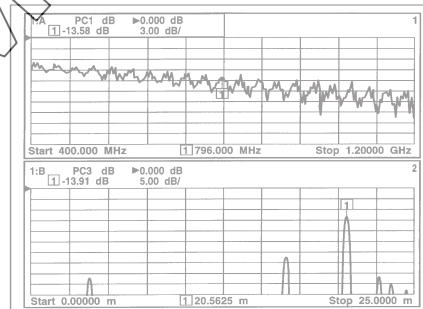

### Specification

#### SCALAR ANALYZER

**NUMBER OF INPUTS** - Four (A, B, C and D)

**DETECTION MODES** - AC and DC

#### DYNAMIC RANGE

AC detection 80 dB (-60 to +20 dBm, 623XA),  
 (-54 to +26 dBm, 623XL)

85 dB typical (-65 to +20 dBm, 623XA),  
 (-59 to +26 dBm, 623XL)

DC detection 70 dB (-50 to +20 dBm, 623XA),  
 (-44 to +26 dBm, 623XL)

**MEASUREMENT POINTS** - User selectable from 2 to 1601

#### NUMBER OF CHANNELS

Two channels, two measurements may be made per channel allowing a total of four simultaneous measurements

**SWEEP TIME**

**Settable Range** - 40 ms to 500 s

**Measurement Times**

401 points <200 ms  
 1601 points <800 ms

**DIRECT VOLTAGE INPUT RANGE**

Input A, B and C 0 V to -4.5 V or 0 V to +4.5 V  
 Input D 0 V to -9 V or 0 V to +9 V  
 (Depending on accessory cable used)  
 (Always displayed as negative value)

**NOISE REDUCTION**

**Averaging**

1 to 1000 (applied per measurement)

**Smoothing**

Aperture settable from 0.01 to 20% of span, resolution 0.01%

**CALIBRATION**

**Path Calibration (Normalization) Types**

Through, short/open, short, open

**INSTRUMENTATION ACCURACY** -  $\pm 0.05\%$

**SYSTEM ACCURACY**

Refer to individual specifications for Detectors and Return Loss Bridges

**DYNAMIC CALIBRATION**

When calibrating 6230A series steps between -30 dBm to +20 dBm  
 When calibrating 6230L series steps between -24 dBm to +20 dBm  
 Note:- For frequency specification refer to Power Reference section

**Output Connector**

N(f), 50  $\Omega$  (Adapter supplied with 6203B and 6204B for use with 3.5 mm and 2.92 mm detectors)

**SYNTHESIZED SWEEP GENERATOR**

**FREQUENCY**

**Range**

6200B 10 MHz to 20 GHz  
 6201B 10 MHz to 8 GHz  
 6202B 10 MHz to 2 GHz  
 6203B 10 MHz to 26.5 GHz  
 6204B 10 MHz to 46 GHz

**Resolution**

0.01 to 26.5 GHz 1 Hz  
 26.5 GHz to 46 GHz 2 Hz

**CW Accuracy**

$\pm 50$  Hz  $\pm$  Frequency standard accuracy to 26.5 GHz  
 $\pm 100$  Hz  $\pm$  Frequency standard accuracy to 46 GHz

**Typical Swept Accuracy**

Step Time	Frequency	
	Up to 2 GHz	>2 GHz
250 $\mu$ s	<5 kHz	<100 kHz
1 ms	<500 Hz	<1.5 kHz
10 ms	<50 Hz	<50 Hz

**POWER**

**6200B/6201B/6202B/6203B standard**

Frequency range (GHz)	Power-levelled (dBm)	
	Guaranteed	Maximum typical
0.01 to 2	-10 to +7	+11
2 to 8	-10 to +6	+8
8 to 18	-10 to +5	+10
18 to 20	-10 to +5	+8
20 to 26.5	-10 to +4	+8

**6204B standard**

Frequency range (GHz)	Power-levelled (dBm)	
	Guaranteed	Maximum typical
0.01 to 2	-10 to +6	+10
2 to 8	-10 to +5	+8
8 to 18	-10 to +5	+8
18 to 20	-10 to +5	+8
20 to 26.5	-10 to +3	+6
26.5 to 40	-10 to 0	+2
40 to 46	-10 to -3	-1

**620XB + Opt.001, 009 (step attenuator)**

Frequency range (GHz)	Power-levelled (dBm)	
	Guaranteed	Maximum typical
0.01 to 2	+5	+9
2 to 8	+4	+6
8 to 18	+3	+7
18 to 20	+2	+5
20 to 26.5	+1	+4
26.5 to 40	-2	+1

For option 001 minimum levelled power -80 dBm

For option 009 minimum levelled power -100 dBm

For option 002 (Field replaceable RF connector) guaranteed output is reduced by 0.5 dB.

**Settable Power Range**

620XB Standard	-20 dBm to +20 dBm
620XB + option 001	-90 dBm to +20 dBm
620XB + option 009	-110 dBm to +20 dBm

**Resolution** - 0.01 dB

**Power Sweep Range** - (From maximum levelled power)

620XB Standard	
0.01 to 26.5 GHz	>25 dB
26.5 GHz to 40 GHz	>10 dB
40 to 46 GHz	>7 dB typical
620XB + option 001	>80 dB
620XB + option 009	>100 dB

**INTERNAL LEVELLING**

**Accuracy** (including flatness at 0 dBm)

All Standard Versions and Option 002 if Fitted  
 0.01 to 26.5 GHz  $\pm 1$  dB,  $\pm 0.5$  dB typical  
 26.5 to 40 GHz  $\pm 1.5$  dB,  $\pm 0.7$  dB typical  
 40 to 46 GHz  $\pm 3.0$  dB typical

Linearity -  $\pm 0.5$  dB over guaranteed levelled power range

To receive a calibration and/or repair quote-RMA from R.A.E. Services Inc.  
 Click here>> [www.raeservices.com/services/quote.htm](http://www.raeservices.com/services/quote.htm)

620XB with option 001, 009 (including option 002 if fitted)  
 10 MHz to 8 GHz <±1 dB (±0.3 dB or ±2% of attenuator setting in dB, whichever is greater)  
 8 GHz to 26.5 GHz <±1 dB (±1 dB or ±4% of attenuator setting in dB, whichever is greater)  
 26.5 GHz to 40 GHz <±1.5 dB (±1 dB or ±4% of attenuator setting in dB, whichever is greater)

#### EXTERNAL LEVELLING

Via rear panel BNC input socket.  
 Accepts signals from a detector (positive or negative) or from the analog output of a power meter (0 to ±1 V)  
 Accuracy depends on levelling technique.

#### SIGNAL PURITY

##### Harmonics

0.01 to 2 GHz <-27 dBc, -35 dBc typical  
 2 to 8 GHz <-35 dBc, -40 dBc typical  
 8 to 26.5 GHz <-40 dBc, -50 dBc typical  
 26.5 to 40 GHz <-20 dBc typical

##### Sub-Harmonics

2 to 26.5 GHz None  
 26.5 to 40 GHz <-40 dBc typical

##### Spurious Signals (Typical)

	30 kHz to 150 kHz	150 kHz to 1 MHz	>1 MHz
0.01 to 2 GHz	<-50 dBc	<-60 dBc	<-60 dBc
2 to 8 GHz	<-50 dBc	<-50 dBc	<-60 dBc
8 to 26.5 GHz	<-50 dBc	<-60 dBc	<-60 dBc
26.5 to 40 GHz	<-40 dBc	<-50 dBc	<-50 dBc

#### Phase Noise

Typical values measured in 1 Hz bandwidth at 20 kHz offset from the carrier in CW mode

0.01 to 2 GHz <-90 dBc/Hz  
 2 to 8 GHz <-78 dBc/Hz  
 8 to 12 GHz <-74 dBc/Hz  
 12 to 20 GHz <-70 dBc/Hz  
 20 to 26.5 GHz <-67 dBc/Hz  
 26.5 to 40 GHz <-57 dBc/Hz

#### Residual FM

In 100 kHz bandwidth in CW mode

0.01 to 2 GHz <1 kHz peak  
 2 to 26.5 GHz <(500 x f) Hz peak  
 26.5 to 46 GHz <(1000 x f) Hz peak  
 where f is the frequency in GHz

#### OUTPUT CONNECTOR

6200B/6201B/6202B Precision N (female), 50 Ω  
 6203B MPC (IFR Precision Connector) 3.5 mm (female), 50 Ω  
 6204B Precision 2.92 mm (female), 50 Ω  
 Option 002 Field replaceable, 50 Ω precision 3.5 mm (female) and N-type (female) - not for 6204B

#### Reverse Input Power

100 mW maximum

#### Source Match (Internally Levelled)

With option 001, 009 minimum return loss specification degrades by up to 5 dB.  
 With option 002 minimum return loss specification degrades by up to 3 dB

#### 6200B/6201B/6202B/6203B

Frequency Range (GHz)	VSWR	Return Loss (dB)	
		Minimum	Typical
0.01 to 0.05	<1.45:1	>15	>17
0.05 to 2	<1.11:1	>26	>33
2 to 8	<1.2:1	>21	>30
8 to 12	<1.35:1	>16.5	>25
12 to 26.5	<1.45:1	>15	>20
<b>6204B</b>			
0.01 to 40	<1.93:1	>10	>12
40 to 46			>10

#### VOLTS/GHZ

Voltage proportional to frequency available from rear panel BNC Voltage/Current output.  
 Range 1 V/GHz or 0.5 V/GHz selectable (20 V maximum in 1 V/GHz mode).  
 Linearity ±1% mV.

#### FIXED RAMP

0 to 10 volt ramp corresponding to frequency start and stop

#### FAULT LOCATION

##### DISTANCE

Units - Metres or feet  
 Accuracy - <0.1% of range or 3 mm, whichever is the larger (for a single fault up to 1 km range)  
 Full Scale - Up to 25 km depending on cable or waveguide loss

#### Minimum Resolution

For two equal amplitude discontinuities using maximum sweep width  
 6200B 1.82 x Vr cm  
 6201B 4.54 x Vr cm  
 6202B 18.28 x Vr cm  
 6203B 1.37 x Vr cm  
 6204B 0.91 x Vr cm  
 Where Vr is the relative velocity of the transmission line

#### DYNAMIC RANGE

Detection	Frequency	
	to 26.5 GHz	26.5 to 40 GHz
AC	80 dB	>40 dB typical
DC	70 dB	>40 dB typical

#### MEASUREMENT TIME (401 POINTS)

Normal mode <250 ms  
 Enhanced mode <500 ms

#### NUMBER OF MEASUREMENT POINTS

User selectable from 51 to 1024

#### POWER METER

##### FREQUENCY RANGE

30 kHz to 46 GHz, dependent upon sensor used

To receive a calibration and/or repair quote-RMA from R.A.E. Services Inc.  
 Click here>> [www.raeservices.com/services/quote.htm](http://www.raeservices.com/services/quote.htm)

**POWER RANGE**

-65 dBm (300 pW) to +35 dBm (3 W), dependent upon sensor used

**INSTRUMENTATION ACCURACY**

<±0.05%

**CORRECTION**

**Calibrator Factor**

Range 0.01% to 200%  
 Resolution 0.01%

**Linearity Factor**

Range 0.1 to 15  
 Resolution 0.1

**Noise (after Auto Zero)**

6910 series 500 nW (-33 dBm)  
 6920 300 pW (-65 dBm)  
 6923/6924 100 nW (-50 dBm)  
 6930 series 15 mW (-18 dBm)

**RESPONSE TIME**

<100 ms

**AVERAGING**

1 to 1000 selected automatically or manually entered

**RESOLUTION**

2 to 4 digits, user selectable

**CHART RECORDER**

Rear panel voltage/current BNC output gives a voltage proportional to measured power

**Sensitivity**

0 V to 5 V; 0 V level dependent upon detector or sensor

**Log Mode**

1 V per decade

**Linear Mode**

Scaling dependent on detector or sensor

**POWER REFERENCE**

**Output Connector**

N(f), 50 Ω. (Adapter supplied with 75 Ω and MPC (IFR Precision Connector), 3.5 mm and 2.92 mm power sensors)

**Frequency** - 50.3 MHz ± 0.1 MHz

**Level** - 1 mW

**Uncertainty** - ±0.7% traceable to National Standards

**Accuracy** - ±1.2% worst case for 1 year

**FREQUENCY COUNTER**

**FREQUENCY RANGE**

6202B 10 MHz to 2 GHz  
 6200B/6201B 10 MHz to 20 GHz  
 6203B/6204B 10 MHz to 26.5 GHz

**RESOLUTION**

**Readout Mode** - 1 Hz to 100 MHz, user selectable

**Swept Mode** - 6 digits

**ACCURACY**

**Readout Mode** - <±25 Hz ± frequency standard error

**Swept Mode** - <(±6th significant figure or ±100 Hz, whichever is greater) ± frequency standard error

**TYPICAL SENSITIVITY**

	6200B/6201B/6202B/6203B	6204B
25 MHz to 10 GHz	<-20 dBm	<-19 dBm
10 GHz to 20 GHz	>-15 dBm	<-14 dBm
20 GHz to 26.5 GHz	>-10 dBm	<-8 dBm

**MAXIMUM INPUT LEVEL** - 0.75 dBm

**DAMAGE LEVEL** - +27 dBm peak

**INPUT CONNECTOR**

6200B/6201B/6202B Precision N-Type (female)  
 6203B/6204B PC (Precision Connector) 3.5 mm (female)  
 Option 002 Field replaceable, 50 Ω precision 3.5 mm (female) and N-type (female)  
 Input Impedance 50 Ω nominal

**FM TOLERANCE**

**Readout Mode**

20 MHz peak to peak at 45 Hz to 10 MHz rate

**Swept Mode**

1.5 MHz peak to peak at 75 Hz to 10 MHz rate

**AM TOLERANCE**

Up to 40% modulation depth for signals within the range of sensitivity and maximum input level

**ACQUISITION TIME**

**Readout Mode**

Typically 2 s for frequencies greater than 300 MHz, for 1 Hz resolution

**Swept Mode**

Typically 150 ms per point for frequencies greater than 300 MHz

**SELECTIVITY**

Typically 25 dB

**PROGRAMMABLE VOLTAGE/CURRENT SOURCE**

**VOLTAGE OUTPUT**

Range -15 V to +15 V  
 Resolution 1 mV  
 Accuracy <±15 mV.  
 Total power supplied not to exceed 2.5 W

**CURRENT OUTPUT**

Range -150 mA to +150 mA  
 Resolution 10 mA  
 Accuracy <±300 mA  
 Total power supplied not to exceed 1.25 W

To receive a calibration and/or repair quote-RMA from R.A.E. Services Inc.  
Click here>> [www.raeservices.com/services/quote.htm](http://www.raeservices.com/services/quote.htm)

**Stability with Temperature** - 10  $\mu$ A/ $^{\circ}$ C

**OUTPUT CONNECTOR** - Rear panel BNC

## DISPLAY

Color active matrix TFT Liquid Crystal Display with 16.5 cm (6.5 in) visible diagonal.

External color monitor (VGA) output on rear panel.

## NUMBER OF CHANNELS

Two. A channel may be configured either as a swept channel for displaying traces or a readout channel for displaying read-outs of values such as power and frequency.

## NUMBER OF TRACES/READOUTS

Four. Maximum of two per channel.

## TITLES

Screen title plus individual measurement titles. Individual title coded to each trace/readout.

## SWEPT CHANNEL CHARACTERISTICS

The horizontal and vertical axes can be configured to display a variety of different measurements. The horizontal axis, referred to as 'Domain', may be defined to display the stimulus such as frequency, power, voltage and current. The vertical axis, referred to as 'Response', may display frequency, power and voltage.

### DOMAIN (Horizontal Axis)

#### Frequency Modes

CW, start/stop, center/span, alternate sweep

#### Frequency Resolution

Settable to 1 Hz, displayed as six digits

#### Frequency Offset

Frequency offset between source and display can be entered to characterize frequency changing devices such as mixers

#### Frequency Scaling

Multiplication factor between source and display can be entered to characterize frequency multipliers and dividers

#### Power Sweep Range

Range depends on option - refer to Synthesized Sweep Generator section

#### Power Offset

Power offset between source and display can be entered for use when measuring amplifiers and attenuators

### RESPONSE (Vertical Axis)

#### Units

dBm, dB, pW to kW, nV to V, VSWR, Hz to GHz

#### Scaling

Manual auto-scale (single shot), continuous auto-scale (every sweep) or user selectable

#### Reference Level Position

Reference level may be set to any graticule line

#### Reference Level Value

-199.99 to +199.99 all units except VSWR  
1 to 100 VSWR

## MEASUREMENT MANIPULATION

### Scalar Detector and Counter Inputs

Display live measurement  
Display trace memory  
Display live measurement relative to trace memory.  
Measurement hold may be applied for each trace.

### Scalar Detector Inputs Only

Any input or ratio of inputs may be assigned to any one or more than one of the traces. A trace may display absolute power, power relative to a path calibration or power minus a trace memory.

### Complex Limit Lines

Four stores of 12 segments each. Each segment defines an upper and a lower limit line or point. Any store can be applied to any trace.

### Input Offsets

An offset in the range -99.99 to +99.99 dB in 0.01 dB steps may be applied per detector input

## MARKERS

Eight per trace plus a separate delta marker

### Marker Functions

Marker, delta marker, minimum, maximum, search left, search right, N-dB bandwidth (with center frequency) marker tracking. Peak to peak response value and optional test against limit

### Marker Resolution

#### Domain (Horizontal)

Frequency - Selectable, either 6 digits or 1 Hz  
Power - 0.01 dB  
Voltage - 1 mV  
Current - 10  $\mu$ A

#### Response (Vertical)

Power - 0.01 dB  
Frequency - Six digits  
Voltage - 1 nV

## READOUT CHANNEL CHARACTERISTICS

### RESOLUTION

Power - 2 to 4 digits, user selectable  
Frequency - 1 Hz to 100 MHz, user selectable  
Voltage - Four digits

### UNITS

Power - dBm, dB, pW to kW  
Frequency - Hz to GHz  
Voltage - nV,  $\mu$ V, mV, V, kV

## MEASUREMENT MANIPULATION

### Marker Readout

Spot readings may be made at the domain value specified by the active marker

### Limit Checking

Upper and lower test limits may be entered

To receive a calibration and/or repair quote-RMA from R.A.E. Services Inc.  
Click here>> [www.raeservices.com/services/quote.htm](http://www.raeservices.com/services/quote.htm)

#### Relative Measurement

To display the measured offset from a previously entered or measured reading

#### Max/Min Hold

To display maximum and minimum values over a period of time for drift measurements

#### Duty Cycle

To display peak power given by average power measured/duty cycle.  
Range: 0.001 to 100%

#### Peaking Meter Display

Analog display to assist when adjusting power levels

#### Input Offsets

An offset in the range -99.99 to +99.99 dB in 0.01 dB steps may be applied per detector or sensor input

### AUXILIARY INPUTS AND OUTPUTS

#### GPIB INTERFACE

GPIB is IEEE 488.1 and 488.2 compatible. The interface has three applications:-

- Instrument control with full talk and listen capability.
- Control of a plotter using HPGL. Plotter output is buffered to permit measurements to proceed whilst plotting.
- Control of a second MTS for mixer measurements. The instruments may be set to sweep with a fixed frequency offset between them.

#### MEMORY CARD INTERFACE

For external storage of data or installation of memory card applications.

#### PARALLEL PRINTER OUTPUT

Compatible with Epson FX, Hewlett Packard DeskJet/LaserJet 4, color DeskJet or Canon BJ series printers. Output is buffered to allow further measurements whilst printing.

#### FREQUENCY STANDARD IN/OUT BNC

1 or 10 MHz input or 10 MHz output (nominally 2 V<sub>pk-pk</sub> into 50 Ω) selectable from front panel.

#### EXTERNAL LEVELLING INPUT BNC

For connection of remote detector or power meter for source levelling.

#### VOLTAGE/CURRENT OUTPUT BNC

User definable to be:

#### Fixed Ramp

0 to 10 volt ramp corresponding to frequency start and stop

#### Volts/GHz

Voltage proportional to frequency output from source

#### Fixed

Fixed voltage or current output for bias measurements

#### Swept V/I

Swept voltage or current for voltage/current domain measurements

#### Chart recorder

Voltage proportional to power level of scalar detector or power meter sensor input

#### EXTERNAL MONITOR

Output to a VGA 640 x 480 standard, color monitor  
Rear panel 15 way 'high density' D type female connector

#### EXTERNAL KEYBOARD

To interface to compact keyboard (optional accessory)

### GENERAL

#### FREQUENCY STANDARD

For synthesized sweep generator and frequency counter

**Internal** - 10 MHz Oven Controlled Crystal Oscillator

**Temperature Stability** - Better than ±5 in 10<sup>3</sup>/0 to 50°C

**Ageing** - Better than 2 in 10<sup>7</sup> per year

**External Input** - 1 or 10 MHz standard rear panel BNC socket

**Output** - 10 MHz rear panel BNC socket

#### MEMORIES

**Trace Memories** - Four

**Settings Stores** - Ten

**Power Sensor Cal Stores**

10 sets of Power Sensor calibration and linearity factor data

**Memory Card** - Extra stores available on memory card

#### 3.5 in DISK DRIVE (OPTION 003)

Up to two hundred trace memories can be stored on a 3.5 in disk.  
Disks can also store the same parameters as the memory card or instrument memories.

#### REAL TIME CLOCK

**Date and Time** - Used to date-stamp hard copies

#### ELECTROMAGNETIC COMPATIBILITY

Conforms with the protection requirements of EEC Council Directive 89/336/EEC.

Complies with the limits specified in the following standards:

EN55011-1991 (Emission)	CISPR11
EN50082-1:1992 (Immunity)	IEC801-2:1991
	IEC801-3:1984
	IEC801-4:1988
EN60555-2:1987 (Mains Harmonics)	IEC555-2

#### SAFETY

Complies with IEC 1010-1. BS EN61010-1 for class 1 portable equipment and is for use in a pollution degree 2 environment. The instrument is designed to operate from an installation category 2 supply.

#### RATED RANGE OF USE (over which full specification is met)

Temperature - 0 to 50°C  
Humidity - Up to 93% RH at 40°C

#### CONDITIONS OF STORAGE AND TRANSPORT

Temperature - -40 to +70°C  
Humidity - Up to 93% RH at 40°C



To receive a calibration and/or repair quote-RMA from R.A.E. Services Inc.  
 Click here>> [www.raeservices.com/services/quote.htm](http://www.raeservices.com/services/quote.htm)

**POWER REQUIREMENTS**

**Switchable voltage ranges**

115 V set	90 to 132 V
230 V set	188 to 265 V

**AC Supply** - 45 to 440 Hz, 500 VA maximum

**DIMENSIONS AND WEIGHT**

Height	Width	Depth
197 mm	389 mm	546 mm
7.75 in	15.3 in	21.5 in

**Weight**

6200B	16 kg (35 lb)
6201B	15 kg (33 lb)
6202B	14.5 kg (32 lb)
6203B	16.25 kg (36 lb)
6204B	17 kg (37.4 lb)

Notes: Guaranteed power range, power accuracy and VSWR are calibrated for the temperature range 0 to 50°C and are subject to the availability of National Standards.  
 Typical performance figures are non-warranted.

**Versions and Options**

When ordering please quote the full ordering number information.

**Ordering Numbers**

6200B	10 MHz to 20 GHz Microwave Test Set (MTS)
6201B	10 MHz to 8 GHz MTS
6202B	10 MHz to 2 GHz RF Test Set
6203B	10 MHz to 26.5 GHz MTS
6204B	10 MHz to 46 GHz MTS

**Options**

Option 001	70 dB step attenuator
Option 002	Field replaceable RF output connector (3.5 mm and N type) (Not available on 6204B)
Option 003	3.5 in Floppy disk drive (standard on 6202B)
Option 008	8.4 GHz Frequency extension (6201B only)
Option 009	90 dB step attenuator (Not available on the 6204B)

**Supplied with**

43123/076	AC supply lead
43138/663	1.5 m power sensor cable
46882/106	Operating manual
6950/069	Input socket cap
23443/822	N(m) to SMA (f) adapter supplied with 6203B and 6204B

**Complementary products**

6146	500 MHz to 18 GHz Pulse Modulator
6148	Pulse Generator and Modulator
6210	259 MHz to 26.5 GHz Reflection Analyzer
6255	50 to 75 GHz Millimeter Wave Reflectometer
6256	75 to 110 GHz Millimeter Wave Reflectometer

**Gain Compression Application**

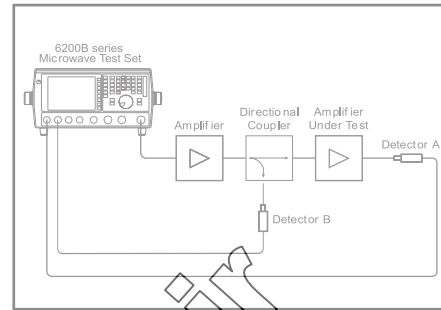

Test Set up for Rated Measurements

The gain compression application runs on the 6200 series Microwave Test Set (MTS) to provide a powerful tool for characterising amplifiers. It is often necessary to characterise the power handling capability of an amplifier. A key aspect of this is the output power at which the gain of the amplifier drops to 1 dB below the small signal value; this is known as the 1 dB compression point. When an amplifier is in compression its characteristics become non-linear. Consequently, signals passing through it will be distorted. Although the 1 dB compression point is the most commonly used, other values are also measured.

For example the 3 dB or 6 dB compression points of high powered devices, such as travelling wave tubes (TWT) or klystrons, are often measured as a definition of amplifier saturation.

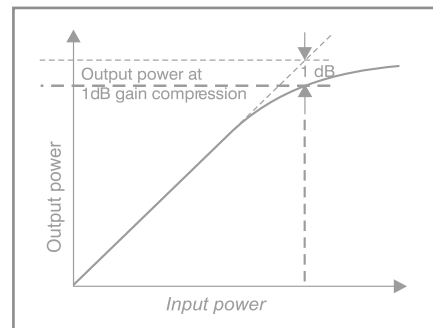

Output power variation against input power showing amplifier going into compression.

For many classes of power amplifier the degree of gain compression varies with frequency. The frequency at which gain compression is greatest determines the power limit of the amplifier. The gain compression software allows the user to perform a swept frequency compression measurement. Deficiencies in power handling become immediately apparent.

The 6200 screen displays the frequency dependant gain compression and the corresponding output power level. Conventional methods when applied to wideband amplifiers can involve considerable testing time, without the near instantaneous results necessary for adjusting performance interactively. This

To receive a calibration and/or repair quote-RMA from R.A.E. Services Inc.  
Click here>> [www.raeservices.com/services/quote.htm](http://www.raeservices.com/services/quote.htm)

capability is especially useful during the design and production stages of broadband amplifiers.

The gain compression software utility generates this display quickly and easily with minimal user interaction, completing the entire measurement typically in under 30 seconds.

### Operation

During the measurement set up, clear diagrams are displayed on the MTS screen showing how to connect the measurement components. The user is guided through calibration and measurement. Consequently, procedural measurement errors are eliminated and test time is minimized.

The basic measurement set up is shown below. The RF output of the MTS is applied directly to the input of the amplifier under test, and a scalar detector connected to the input A measures the amplifier output.

It is possible to modify the basic set up by the use of attenuators at either the input or output stages of the amplifier or by the use of a pre-amplifier. A pre-amplifier may be necessary when testing low gain, high compression point amplifiers which the standard MTS may not be able to drive into compression.

The power level of the source is set to an initial level in the small signal gain region of the amplifier. A frequency sweep is then performed to give a display of the small signal gain against frequency. The output power of the MTS source is then increased at each measurement point in an iterative process until the amplifier is at the 1 dB compression point at all frequencies. (Compression values other than 1 dB can be selected before the measurement is made).

Two traces are then displayed; one is the gain at the 1 dB compression point as a function of frequency, the other is the amplifier power output (or input) at the compression point as a function of frequency.

When the measurement has completed the user can store the results to non volatile memory or generate a hard copy print or plot as necessary. This whole process typically takes less than 30 seconds and enables full and comprehensive testing of amplifiers that may not otherwise have been possible.

### GPIB Control

For automated measurements the application can be controlled over the standard MTS GPIB. In this way amplifier production can also be simplified with automated pass/fail analysis of the measurement within the test program.

### Remote Levelling Capability

The software can also be used for fast power levelling of the MTS at the end of a test cable. This facility allows the user to connect a long RF cable to the RF output of the MTS and achieve levelled power of a user defined value at the test port of the cable. In this way the frequency response of devices between the MTS output and the test port can be eliminated. Remote levelling takes typically less than

one minute and removes the need for a separate power meter which is usually necessary with alternative systems.

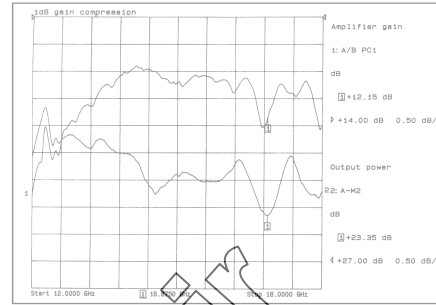

Top trace shows amplifier gain against frequency. Lower trace shows amplifier output power against frequency. All frequency measurement points are at 1 dB compression.

## Specification

Runs on any 6200 series Microwave test Set (MTS) with issue 2.0 software or higher. It is recommended that the MTS is fitted with the optional internal attenuator. (Option 001 or 009).

### Measurements Provided

Amplifier gain, input power or output power as a function of frequency at N dB compression (where N is in the range 100 to -100 dB).

### Measurement Definitions

Supports single detector and ratio measurements

### Additional Capability

Correction for attenuators on amplifier output. Correction for attenuation or pre amplification on amplifier input using ratio measurement. (Pre amplification may be necessary in order to compress low gain high power amplifiers).

### Source Control

Number of measurement points 2 to 1601  
User specified maximum RF output power.

### RF Performance

As for MTS. See separate specification.

## Versions and Accessories

When ordering please quote the full ordering number information.

### Ordering Numbers

59000/265 Gain Compression software utility for 6200 series Microwave Test Set (MTS).  
Supplied on MTS memory card

### Supplied with

46882/232 Operating manual

To receive a calibration and/or repair quote-RMA from R.A.E. Services Inc.  
Click here>> [www.raeservices.com/services/quote.htm](http://www.raeservices.com/services/quote.htm)

## Guided Measurement Application

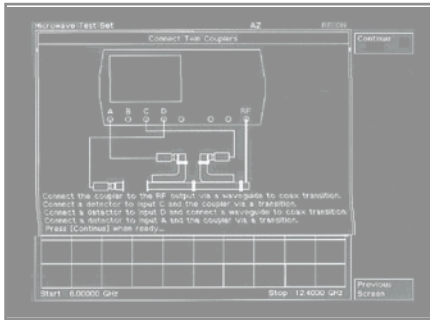

Connection diagram for measurement of return loss and insertion loss in a waveguide feed using couplers

When installing and commissioning a new RF or microwave radio link the quality of the antenna and antenna feed, waveguide or coaxial, is fundamental to the overall link performance. Return loss is the principal measurement made to quantify the quality of the antenna and feed installation. Some users prefer to measure VSWR which is an alternative presentation of the same measurement.

With the guided measurements application the user is lead through the measurements. It is not necessary to have a comprehensive understanding of the MTS as the application presets key instrument parameters. Prompts and message boxes appear for the user to enter values specific to their system such as start and stop frequencies. Large on-screen diagrams show the user how to connect up the necessary components such as detectors, couplers and test heads.

The guided measurements application supports measurements on both waveguide and coaxial systems. Should the system under test fail to meet the specified return loss (VSWR) measurement limit, the same application can be used to guide the user through a fault location measurement. Fault location identifies the position of a fault or discontinuity such as might occur at a coax connector or waveguide flange.

The 6200 series MTS is designed for people to install and maintain RF and microwave antenna systems. The excellent performance along with the integrated and compact design mean that it can be operated in all locations with confidence. When used with the guided measurements application, fast accurate and repeatable measurements are guaranteed. This results in minimum installation time and quick repair of faulty sites.

### Performing the Measurement

The application commences by prompting for the following information

- Type of measurement return loss, fault location, insertion loss
- Transmission line medium waveguide, coax
- equipment to be used test head, waveguide couplers

A diagram is then displayed to show the user how to connect the components to make the measurement. Messages prompt for data entry of parameters such as start and stop frequencies.

The user is then guided through the appropriate calibration for the chosen measurement. This routine minimizes errors to give the best possible measurement accuracy.

After calibration, on-screen diagrams show how to connect the equipment to measure the transmission line under test. The MTS will now display the trace of the measurement or measurements selected. Operation of the MTS returns to the standard user interface which allows markers to be positioned and traces plotted or stored to memory for further examination at a later date.

### Transmission Line Database

A separate memory card is available which contains the fundamental parameters of relative velocity, attenuation and cut off frequency for the most commonly used coaxial and waveguide transmission lines. This transmission line database complements the use of the guided measurement application and eliminates the need to carry transmission line manufacturers catalogues to the antenna site.

### Versions and Accessories

When ordering please quote the full ordering number information.

#### Ordering Numbers

59000/280 Guided measurements application for 6200 series Microwave Test Set (MTS). Supplied on MTS memory card.

#### Supplied with

46882/241 Operating Manual

#### Complementary Product

59000/264 Transmission Line Database

To receive a calibration and/or repair quote-RMA from R.A.E. Services Inc.  
 Click here>> [www.raeservices.com/services/quote.htm](http://www.raeservices.com/services/quote.htm)

**6200B RF AND MICROWAVE TEST SETS ACCESSORIES**

Order numbers	Versions		
<b>6230A/L SCALAR DETECTORS</b>			
<b>Scalar Detectors (with EEPROM correction)</b>			
Standard Detectors			
(-65 dBm to +20 dBm) typical			
6230A series	10 MHz to 20 GHz, N type (m)		
6230A	1 MHz to 3 GHz, N Type (m)		
6232A	10 MHz to 26.5 GHz, 3.5 mm (m)		
6233A	10 MHz to 46 GHz, 2.92 mm (m)		
6234A	Low VSWR detectors (-59 dBm to +26 dBm Low VSWR) typical		
6230L series	10 MHz to 20 GHz, N type (m)		
6230L	10 MHz to 26.5 GHz, 3.5 mm (m)		
6233L	10 MHz to 46 GHz, 2.92 mm (m)		
6234L			
<b>Autotesters</b>			
59999/151	10 MHz to 18 GHz 7 mm	54311/175	N (m) to N (m)
59999/158	10 MHz to 18 GHz N (m)	54311/167	N (m) to N (f)
59999/159	10 MHz to 18 GHz N (f)	54311/174	N (f) to N (f)
59999/152	10 MHz to 26.5 GHz 3.5 mm WSMA (m)	54311/176	N (f) to 3.5 mm (f)
59999/166	10 MHz to 26.5 GHz 3.5 mm WSMA (f)	54311/177	N (m) to 3.5 mm (f)
59999/168	10 MHz to 40 GHz 2.92 mm (m)	54311/178	N (m) to 3.5 mm (m)
59999/169	10 MHz to 40 GHz 2.92 mm (f)	54311/185	N (f) to 3.5 mm (m)
<b>RF Bridge</b>			
59999/170	5 MHz to 2 GHz N (f)	54311/137	N (m) to TNC (f)
<b>Fault Locators</b>			
6242F	10 MHz to 3 GHz, N (f)	54311/138	N (m) to TNC (m)
6242M	10 MHz to 3 GHz, N (m)	54311/139	N (f) to TNC (f)
6240F	10 MHz to 20 GHz, N (f)	54311/186	N (f) to TNC (m)
6240M	10 MHz to 20 GHz, N (m)	54311/203	7 mm to N (f)
6243F	10 MHz to 26.5 GHz, 3.5 mm (f)	54311/204	7 mm to TNC (m)
6243M	10 MHz to 26.5 GHz, 3.5 mm (m)	54311/205	7 mm to TNC (f)
6241	10 MHz to 20 GHz, 7 mm	54311/136	TNC (m) to TNC (m)
<b>Microwave Ruggedized Cables for Fault Locators</b>			
54311/197	1.5 m, 20 GHz, N (m) to Right Angle N (m)	54311/107	3.5 mm (f) to 3.5 mm (f)
54311/198	3.0 m, 20 GHz, N (m) to Right Angle N (m)	54311/165	3.5 mm (m) to 3.5 mm (f)
54311/201	1.5 m, 26.5 GHz, 3.5 mm (m) to Right Angle 3.5 mm (m)	54311/164	3.5 mm (m) to 3.5 mm (m)
54311/202	3.0 m, 26.5 GHz, 3.5 mm (m) to Right Angle 3.5 mm (m)	54311/162	2.92 mm (m) to 2.92 mm (m)
<b>RF Ruggedized Cables for Fault Locators</b>			
54311/199	1.5 m, 3 GHz, N (m) to Right Angle N (m)	54311/206	2.92 mm (m) to 2.92 mm (f)
54311/200	3.0 m, 3 GHz, N (m) to Right Angle N (m)	54311/207	2.92 mm (f) to 2.92 mm (f)
<b>Transmission Line Test Head</b>			
56581/001	10 MHz to 20 GHz Transmission Line Test Head, 6581	54311/133	N (f) to SMA (f)
56583/001	10 MHz to 26.5 GHz Transmission Line Test Head, 6583	54311/134	N (m) to SMA (f)
<b>Microwave Ruggedized Cables for Transmission Line Test Heads</b>			
54311/116	1.5 m, 20 GHz, N (m) to N (m)	54311/135	TNC (m) to SMA (f)
54311/109	3.0 m, 20 GHz, N (m) to N (m)	<b>Miscellaneous Electrical Cables</b>	
54311/117	1.5 m, 26.5 GHz, 3.5 mm (m) to 3.5 mm (m)	54311/170	Positive Voltage Measurement Cable
54311/110	3.0 m, 26.5 GHz, 3.5 mm (m) to 3.5 mm (m)	54311/112	Negative Voltage Measurement Cable
<b>Power Sensors</b>			
<b>6910 Series Medium Power</b>			
56910/900	10 MHz to 20 GHz, N type (m)	43129/189	GPIO Cable
56911/900	10 MHz to 20 GHz, 7 mm	43139/042	RF Cable, 50 Ohm BNC - BNC, 1.5 m
56912/900	30 kHz to 4.2 GHz, N type (m)	46884/560	Partial Printer Interface Cable
56913/900	10 MHz to 26.5 GHz, MPC 3.5 mm (m)	43137/604	Cable Assembly (Autotester)
56914/001	10 MHz to 40 GHz, 2.92 mm (m)	<b>Standard Microwave Cables</b>	
56914/002	10 MHz to 40 GHz, 2.92 mm (m) plus waveguide 22 transformer	54351/023	0.5 m, 20 GHz, N (m) to N (m)
56914/003	10 MHz to 46 GHz, 2.92 mm (m)	54351/025	0.5 m, 26.5 GHz, 3.5 mm (m) to 3.5 mm (m)
56919/900	30 kHz to 3 GHz, N type 75 W	54351/027	0.5 m, 40 GHz, 2.92 mm (m) to 2.92 mm (m)
<b>6920 Series Low Power</b>			
56920/900	10 MHz to 20 GHz, N type (m)	<b>Attenuators</b>	
56923/900	10 MHz to 26.5 GHz, MPC 3.5 mm (m)	56534/901	Precision Fixed Coaxial Attenuator 3 dB DC to 18 GHz 5 W, N(m) to N(f)
56924/001	10 MHz to 40 GHz, 2.92 mm (m)	56534/902	Precision Fixed Coaxial Attenuator 6 dB DC to 18 GHz 5 W, N(m) to N(f)
56924/002	10 MHz to 40 GHz, 2.92 mm (m) plus waveguide 22 transformer	56534/903	Precision Fixed Coaxial Attenuator 10 dB DC to 18 GHz 5 W, N(m) to N(f)
56924/003	10 MHz to 46 GHz, 2.92 mm (m)	56534/904	Precision Fixed Coaxial Attenuator 20 dB DC to 18 GHz 5 W, N(m) to N(f)
<b>6930 Series High Power</b>			
56930/900	10 MHz to 18 GHz, N type (m), 35 dBm	<b>Application and memory cards</b>	
56932/900	30 kHz to 4.2 GHz, N type (m), 35 dBm	59000/265	Gain Compression Application
56934/001	10 MHz to 40 GHz, 2.92 mm (m), 30 dBm	59000/280	Guided Measurements Application
56934/002	10 MHz to 40 GHz, 2.92 mm (m) plus waveguide 22 transformer 30 dBm	59000/264	Transmission Line Database
56934/003	10 MHz to 40 GHz, 2.92 mm (m), 30 dBm	59000/182	128k Blank Memory Card
56930/002	10 MHz to 18 GHz, N type (m), 45 dBm	59000/186	512k Blank Memory Card
56932/002	30 kHz to 4.2 GHz, N type (m), 45 dBm	59000/190	MTS PC-Utilities Software
<b>Fault Locator, Scalar Detector, Power Sensor DC Cables</b>			
43138/663	1.5 m, DC Cable	59000/227	MIPlot Software Pack
43138/664	3.0 m, DC Cable	54441/004	Memory Card Reader/Writer Unit
43138/665	10 m, DC Cable	54441/016	AC Adapter - UK style for Reader/Writer
43138/666	25 m, DC Cable	54441/017	AC Adapter - European style for Reader/Writer
43138/667	50 m, DC Cable	54441/018	AC Adapter - USA style for Reader/Writer
(For longer lengths contact your local IFR sales office).			
<b>Power Splitters/Dividers</b>			
54311/123	Power Splitter DC to 18 GHz, Type N	54127/309	Rack Mount Kit for 6200B
54311/124	Power Splitter DC to 26.5 GHz, 3.5 mm	54127/311	Rack Mount Kit for 6200B and 6210
54311/161	Power Splitter DC to 40 GHz, 2.92 mm	54124/027	Front Storage Cover
54311/187	Power Divider DC to 18 GHz	54121/034	Detector Input Socket Cap
54311/188	Power Divider DC to 26.5 GHz	46880/064	Service Manual
<b>RF Ruggedized Cables for Bridges and Dividers</b>			
54311/195	1.5 m, 3 GHz, N (m) to N (m)	54112/157	Soft Carrying Case
54311/196	3.0 m, 3 GHz, N (m) to N (m)	54112/160	Hard Flight Case for 6200B and 6210
<b>Fixed Loads</b>			
54421/020	7 mm Fixed Load	54112/161	Hard Flight Case for 6200B.
54421/021	3.5 mm (f) Fixed Load	54152/001	3.5 mm Torque Wrench for 6200B
54421/022	3.5 mm (m) Fixed Load	54211/008	Compact Keyboard
54421/023	N (m) Fixed Load		
54421/024	N (f) Fixed Load		

To receive a calibration and/or repair quote-RMA from R.A.E. Services Inc.  
Click here>> [www.raeservices.com/services/quote.htm](http://www.raeservices.com/services/quote.htm)

Calibration & Repair  
[www.raeservices.com](http://www.raeservices.com)



To receive a calibration and/or repair quote-RMA from R.A.E. Services Inc.  
Click here>> [www.raeservices.com/services/quote.htm](http://www.raeservices.com/services/quote.htm)

Calibration & Repair  
[www.raeservices.com](http://www.raeservices.com)

To receive a calibration and/or repair quote-RMA from R.A.E. Services Inc.  
Click here>> [www.raeservices.com/services/quote.htm](http://www.raeservices.com/services/quote.htm)

Calibration & Repair  
[www.raeservices.com](http://www.raeservices.com)



To receive a calibration and/or repair quote-RMA from R.A.E. Services Inc.  
Click here>> [www.raeservices.com/services/quote.htm](http://www.raeservices.com/services/quote.htm)

IFR - "Working together to create solutions for the world of communications."

IFR is a world leader in developing leading edge test and measurement equipment. The priority at IFR is to understand your communications test needs and respond to them. IFR has the flexibility and expertise to create just the right test solution for you. We understand that just as you are the expert in designing wireless products, we are expert in wireless test.

Combining the quality of our test products with their reliability, excellent price/performance ratio and minimal requirements for maintenance, every IFR test system represents an outstanding lifetime value.

IFR - "Working together with our customers to be flexible and innovative in providing effective test solutions for the rapid design, manufacture and maintenance of communications systems."

The added value IFR includes with each and every test set we sell will make you more productive. We offer a two-year standard warranty on all products and we will continue to support your product for five years beyond its final production. Our outstanding Customer Service Department offers calibration, out-of warranty repairs and consulting. Our Sales and Training Departments offer clear and concise product information with realistic performance specifications, technology training and application training. Our experienced engineers will help you develop application software and through continuous improvement programs, upgrades are always available.

IFR will continue to build upon our technology resources with an aggressive commitment that will enable you to excel in some of the world's most dynamic, high growth markets.

**CHINA**

Tel: [+86] (10) 6467 2823  
Fax: [+86] (10) 6467 2821

**FRANCE**

Tel: [+33] 1 60 79 96 00  
Fax: [+33] 1 60 77 69 22

**GERMANY**

Tel: [+49] (8131) 29260  
Fax: [+49] (8131) 2926130

**HONG KONG**

Tel: [+852] 2832 7988  
Fax: [+852] 2834 5364

**LATIN AMERICA**

Tel: [+1] (972) 899 5150  
Fax: [+1] (972) 899 5154

**SCANDINAVIA**

Tel: [+45] 9614 0045  
Fax: [+45] 9614 0047

**SPAIN**

Tel: [+34] (91) 640 11 34  
Fax: [+34] (91) 640 06 40

**UNITED KINGDOM**

Tel: [+44] (0) 1438 742200  
Toll Free: [+44] (0800) 282 388 (UK only)  
Fax: [+44] (0) 1438 727601

**USA**

Tel: [+1] (316) 522 4981  
Toll Free: [+1] (800) 835 2352 (US only)  
Fax: [+1] (316) 522 1360

email **[info@ifrsys.com](mailto:info@ifrsys.com)**

web **[www.ifrsys.com](http://www.ifrsys.com)**

As we are always seeking to improve our products, the information in this document gives only a general indication of the product capacity, performance and suitability, none of which shall form part of any contract. We reserve the right to make design changes without notice. All trademarks are acknowledged. Parent company IFR Systems, Inc. © IFR 2001.

Part No. 46891/054

Issue 5

08/2001

Calibration & Repair  
[www.raeservices.com](http://www.raeservices.com)

